

# *Investigation of hydrophobic porous electrodes.*

## *I. Differential capacitance by a low frequency a.c. impedance technique*

J. McHARDY, J. M. BARIS, P. STONEHART

*Advanced Fuel Cell Research Laboratory, Power Systems Division, United Technologies Corporation, Middletown, Connecticut 06457, USA*

Received 20 October 1975

---

A simple a.c. technique has been developed for measuring the double layer capacitances of porous electrodes. A small alternating potential ( $\pm 15$  mV at 1 Hz) is applied potentiostatically to the test electrode and the phase and amplitude of the alternating current are monitored on an oscilloscope by the method of Lissajous figures. The value of the double layer capacitance for carbon and gold, together with the potential dependence for the gold capacitance, agree with published data for smooth electrodes. The technique can follow changes in the interfacial surface area between a porous electrode and the electrolyte as well as providing information about surface processes on finely divided materials.

---

### 1. Introduction

One obstacle to the development of a practical fuel cell has been a lack of fundamental electrodic data applicable to *porous* electrodes. Results obtained exclusively on smooth electrodes are not adequate (cf. the influence of Pt crystallite size on electrode kinetics [1]) and parallel data are needed for porous electrodes. In order to generate such data, certain characteristics of the experimental electrodes must be determined and the purpose of this series of papers is to describe techniques that we have developed for making these determinations. The first requirement for interpreting electrodic results is a knowledge of the interfacial area between electrode and electrolyte but for a porous electrode, measurement of this parameter is rarely straightforward. In simple cases, a measurement of the specific surface area ( $\text{cm}^2 \text{cm}^{-3}$ ) may be sufficient and a 'sampling' technique [2] can be employed. In more realistic cases, however, such as a partially hydrophobic fuel cell electrode or a battery electrode with pore sizes that vary with depth, the interfacial area must be measured on the whole electrode. Attempts have been made to adapt smooth electrode techniques for porous electrodes but with little success. One

exception is the use of the hydrogen deposition charge as a measure of platinum surface area. The equilibrium coverage of hydrogen on platinum at 0.0 V versus the reversible hydrogen electrode (R.H.E.) approximates a 1:1 atomic ratio and is routinely used to measure platinum surface areas in flooded porous electrodes [3]. While this technique is very useful, it is rather limited in scope. Measurement of differential double layer capacitance would be more widely applicable and considerable progress has been made in this direction [4]. The most reliable data on double layer capacitance come from impedance measurements but for porous electrodes, a.c. bridge techniques are impractical and recent workers have concentrated on techniques involving non-sinusoidal perturbations [4].

The essential problem in applying an a.c. technique to a porous electrode reduces to that of making low frequency impedance measurements. Since the impedance of a capacitor is inversely proportional to the product of frequency and capacitance, a low frequency can compensate for a large capacitance and raise the impedance to measurable levels. However, there is a more fundamental reason why low frequencies must be used. Each pore in a porous electrode behaves like a

transmission line [2, 5] and an a.c. voltage applied at one end is attenuated as it propagates down the pore. According to the model of de Levie [5], the signal experienced at a depth  $z$  inside a pore is diminished in amplitude by a factor

$$\exp - z(\omega rc/2)^{1/2}$$

and delayed in phase by an angle equal to the argument of the above exponent. The quantities  $r$  and  $c$  represent the resistance and capacitance per unit length of the pore. Clearly then, a low frequency will tend to reduce the distortion of a test signal and favour a response that characterizes the whole electrode.

Preliminary work with carbon black electrodes revealed that an a.c. frequency below 10 Hz was needed before the full double layer capacitance could be measured. Accordingly, 1 Hz was adopted as the standard test frequency. Theoretical prediction of the appropriate test frequency was not attempted because the electrode structure was too complex. Other types of porous electrode used in the study (platinum black and gold black) were coarser than the carbon black electrodes and errors at 1 Hz would be correspondingly smaller.

The low frequency impedance measurements were made by the method of Lissajous figures [6]. The method proved adequate for our purposes and no need was found for the greater precision of a technique involving lock-in amplifiers or phase sensitive detectors [7].

## 2. Experimental

Most tests were performed in hot concentrated o-phosphoric acid (160° C, 96% H<sub>3</sub>PO<sub>4</sub>). Potentials were referred to a reversible hydrogen electrode in the same solution and measured with an electrometer (Keithley model 610BR). The d.c. potential of the working electrode was set on a potentiostat (Wenking model 68TAI) and a small a.c. voltage was superimposed on this potential by means of a function generator (Hewlett Packard model 202A with attenuated output). The period of the a.c. signal in ms was monitored with a digital counter (Monsanto model 101C). A frequency of 1 Hz was found to be the best compromise between the requirements of accuracy and precision. Frequencies of 10 Hz and above tended to underestimate the double layer capacitance while noise

problems became severe at 0.1 Hz or below. Measured capacitance values were insensitive to a.c. signal amplitude up to ± 50 mV but noise became a problem at the lowest amplitudes. Most measurements were made with a signal amplitude of ± 15 mV.

Measurements were made on two types of electrodes. The first type consisted of a high surface area powder ('black') sandwiched between discs of porous gold. The weight of powder (chosen to yield capacitances in the range 0.1 to 0.3 f for the electrode) was 5 mg for carbon black, 20 mg for platinum black and 100 mg for gold black. The capacitance of the porous gold discs was found to be negligible by comparison with the powders. The second type of electrode was a conventional hydrophobic electrode containing PTFE and carbon black [1]. In a test to determine the influence of a Faradaic current upon capacitance measurements, the carbon black was impregnated with ~ 12 wt% of platinum before it was made into a hydrophobic electrode. All electrodes were tested in a screw-cap holder of PTFE. Except where noted, an atmosphere of nitrogen was maintained behind the electrodes.

The Lissajous figures were generated on an oscilloscope (Tektronix model 564 with matched plug-in amplifiers) as follows: the alternating voltage was applied to the vertical amplifier of the oscilloscope and the signal produced by the alternating current in a 1 Ω resistor was applied to the horizontal amplifier. In general, each signal included a d.c. component but this was easily backed out with a battery and potentiometer circuit. Since the two alternating signals had the same frequency, the Lissajous figure was an ellipse. The phase angle,  $\theta$ , between current and voltage may be calculated from the dimensions of the ellipse in a variety of ways [6] but in most cases the relationship

$$\sin \theta = \alpha\beta/xy$$

was used, where  $\alpha$  and  $\beta$  are the minor and major axes of the ellipse respectively and  $x$  and  $y$  are the projections of the ellipse on the cartesian axes. The formula is valid irrespective of the relative scales of the  $x$  and  $y$  axes but in our tests both scales were 5 mV cm<sup>-1</sup>. The impedance was thus given directly by

$$Z = y/x.$$

The series resistance and capacitance corresponding to the observed impedance were then obtained from simple a.c. theory:

$$R = Z \cos \theta \quad \text{and} \quad C = (\omega Z \sin \theta)^{-1}.$$

In order to determine the reliability of the technique, measurements were performed on the dummy cell in Fig. 1a. The values of the components (chosen arbitrarily) were measured individually on a Wayne Kerr B642 transformer bridge at an a.c. frequency of 1591 Hz. The potentiostatic technique applied to the dummy cell at the same frequency gave values for  $R$  and  $C$  of 0.57  $\Omega$  and 625  $\mu\text{f}$ , i.e., within 6% of the corresponding components in the dummy cell.

Impedance data were analyzed on the basis of the two equivalent circuits shown in Figs 1b and 1c. The series  $R$ - $C$  combination in Fig. 1b represents the simplest possible equivalent circuit for an electrode and Fig. 1c represents the next simplest. Since a single ellipse provided enough information to define two parameters, only one measurement (at 1 Hz) was needed to evaluate  $R$  and  $C$  (Fig. 1b). Resolution of the three component circuit, however, (Fig. 1c) required an extra measurement and this measurement was made at a frequency in the kHz range. The high frequency was chosen such that the ellipse just collapsed into a straight line, i.e., the impedance of  $C$  became negligible, and the total impedance (given by the

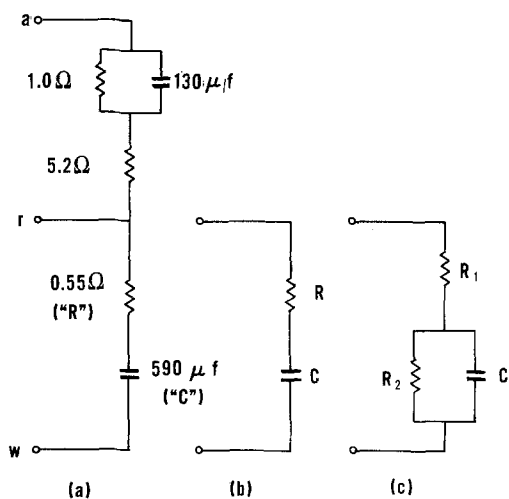

Fig. 1. (a). Dummy Cell; a – auxiliary electrode; r – reference electrode; w – working electrode. (b) Two-component equivalent circuit for a porous electrode. (c) Three-component equivalent circuit for a porous electrode.

slope of the line) was equal to  $R_1$ . Interruptor measurements of the ' $iR$  drop' yielded very similar estimates of this resistance.

### 3. Results

To test the validity of the a.c. technique, the impedance of a gold black electrode was measured at room temperature in 1 M  $\text{HClO}_4$  solution and the resulting value for  $C$  was compared with the double layer capacitance measured on smooth polycrystalline gold by Schmid and Hackerman [8]. The comparison is shown in Fig. 2, where our data points are superimposed on their curve of capacitance versus potential. In order to optimize the fit, we treated the surface area of the gold black as an adjustable parameter. The value for the surface area that gave the best fit was 5.7  $\text{m}^2 \text{gm}^{-1}$ , some 30% lower than the area expected from B.E.T. measurements.

The dependence of  $C$  upon electrode potential in hot phosphoric acid is shown for different materials in Fig. 3. Each measurement was made one min after setting the potential. Reproducible starting conditions were achieved by holding the electrode at 0.10 V for one min between measurements.

The contribution to  $R$  from the electrolyte outside the electrode was varied by moving the Luggin capillary of the reference electrode. The resulting variations in equivalent circuit elements are shown in Table I.

The influence of Faradaic current upon the apparent value of  $C$  is shown in Fig. 4. The figure

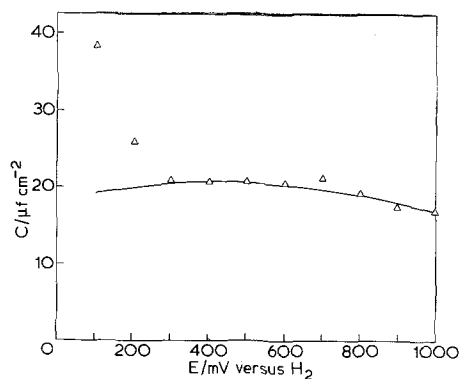

Fig. 2. Dependence of  $C$  upon potential for gold in 1M  $\text{HClO}_4$  at 25° C according to Schmid and Hackerman [8] (solid line) and the present work ( $\Delta$ ).

Table 1. Analysis of impedance data for a PTFE bonded carbon black electrode at 0.30 V for different positions of the Luggin capillary. The two equivalent circuits are shown in Fig. 1.

Estimated distance ( $\pm 1$ mm) of Luggin capillary from elec- trode in mm	Two-component equivalent circuit		Three-component equivalent circuit		
	$R, \Omega$	$C, f.$	$R_1, \Omega$	$R_2, \Omega$	$C, f.$
6	1.50	0.147	1.36	8.8	0.145
4	1.06	0.128	0.93	12.3	0.127
2	0.63	0.120	0.52	15.0	0.123
1	0.43	0.123	0.36	23.6	0.123

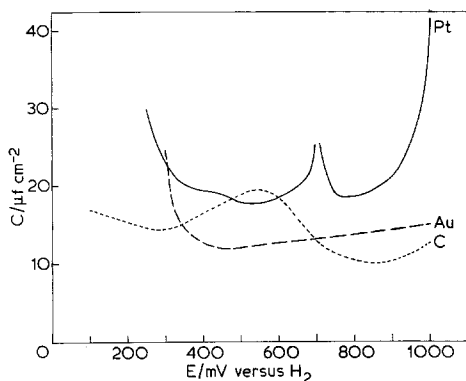

Fig. 3. Dependence of  $C$  upon electrode potential for carbon black, gold black and platinum black in 96%  $H_3PO_4$  at  $160^\circ C$ .

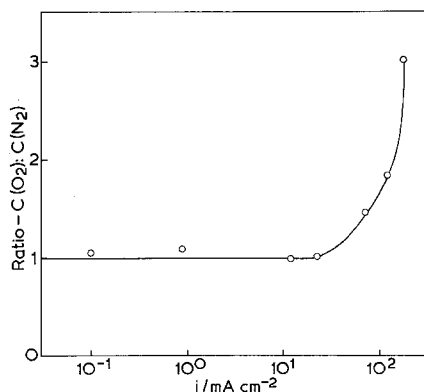

Fig. 4. Ratio of  $C$  measured under  $O_2$  to the value measured under  $N_2$  at the same potential as a function of  $O_2$  reduction current (96%  $H_3PO_4$ ;  $160^\circ C$ ).

compares the capacitances of a platinumized carbon black electrode measured under oxygen and nitrogen, respectively, at a series of potentials. Agreement was within experimental error ( $C_{O_2} : C_{N_2} = 1$ ) until the potential reached the point

where the oxygen reduction current was  $\sim 50$  mA. At lower potentials (higher currents) the ratio  $C_{O_2} : C_{N_2}$  increased rapidly with Faradaic current.

In the absence of PTFE the capacitance of carbon black remained essentially invariant with time. Application of a triangular voltage programme (0.1–1.0 V at 0.1 Hz) to a PTFE bonded carbon black electrode caused the capacitance to increase with time as shown in Fig. 5a. The final capacitance of a PTFE bonded carbon black electrode tended to decrease with increasing PTFE as shown in Fig. 5b.

## 4. Discussion

### 4.1. The equivalent circuit

The impedance of any network of resistors and capacitors can be matched at a given frequency by a combination of one resistor,  $R$ , and one capacitor,  $C$ . The values of  $R$  and  $C$  will vary with frequency and in general will bear no relationship to the values of individual components in the original network. There is thus no *a priori* reason why the capacitance derived from an  $R$ – $C$  series equivalent circuit (Fig. 1b) should equal the double layer capacitance of a porous electrode. Nevertheless, several arguments can be raised in support of this correlation.

(a) the value of  $C$  is reasonably independent of frequency and of changes in  $R$  (Table I). This observation implies that  $C$  represents a real capacitance rather than an algebraic combination of resistance and capacitance terms.

(b) the value calculated for  $C$  is relatively insensitive to the choice of equivalent circuit. For example, the value of  $C$  derived from a two com-

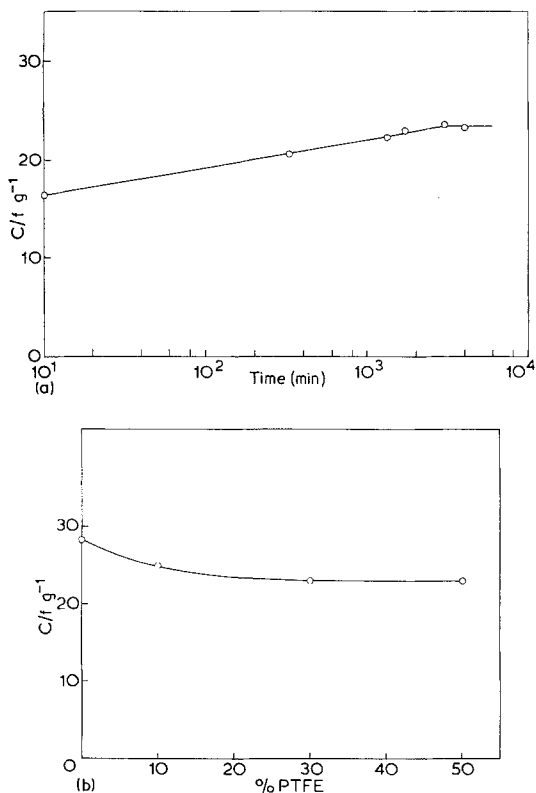

Fig. 5 (a). Dependence of  $C$  upon cycling time for a PTFE bonded carbon black electrode ( $E = 300$  mV; 96%  $H_3PO_4$ ;  $160^\circ C$ ). (b) Dependence of  $C$  upon wt% PTFE in a carbon black electrode ( $E = 300$  mV; 96%  $H_3PO_4$ ;  $160^\circ C$ ).

ponent circuit (Fig. 1b) is typically within 5% of the value derived from a three component circuit (Fig. 1c).<sup>\*</sup> A comparison of  $C$  values derived from these two equivalent circuits appears in Table I. Elsewhere in the paper, the  $C$  values given are those derived from the two component equivalent circuit.

(c) good agreement is obtained with double layer capacitance results measured on smooth electrodes [8] (Fig. 2) considering the factor of over  $10^4$  difference in the surface areas.

Interpretation of the  $R$  components in an equivalent circuit is less straightforward. Undoubtedly,  $R_1$  in the three component circuit (Fig. 1c) corresponds to the ionic resistance between the front face of the porous electrode and the tip of the Luggin capillary but no direct interpretation can be made for  $R_2$ .

<sup>\*</sup> The precise condition for agreement within 5% is that the term  $[\omega (R - R_1) C]^2$  be less than 0.05

## 4.2. The effect of potential

**4.2.1. Carbon black.** The double layer capacitance for carbon black electrodes in 96% phosphoric acid at  $160^\circ C$  lies between 10 and  $20 \mu f cm^{-2}$ , in agreement with published data [4]. The highest values occurred in the vicinity of 0.5 V. This maximum in the  $C-E$  curve can be greatly enhanced by prior oxidation of the carbon and probably constitutes a pseudocapacitance arising from some surface redox couple of the type quinone/hydroquinone [9].

**4.2.2. Gold black.** In 96% phosphoric acid at  $160^\circ C$ , the double layer capacitance of gold was close to  $12 \mu f cm^{-2}$  over most of the potential range investigated but at potentials below 0.4 V there was a sharp increase in the capacitance. In 1 M perchloric acid at  $25^\circ C$ , the double layer capacitance was relatively constant above 0.3 V but below that potential the capacitance increased sharply. The behaviour at low potentials differs from that observed by Schmid and Hackerman [8], reflecting a greater susceptibility of our slow measurements to interference by Faradaic processes.

**4.2.3. Platinum black.** The capacitance versus potential curve in 96% phosphoric acid at  $160^\circ C$  exhibited several interesting features. Rising portions of the curve at either end can be attributed to the Faradaic processes of H deposition (low potentials) and Pt oxidation (high potentials). The sharp peak at 0.7 V suggests a reversible Faradaic reaction but its nature is open to speculation. No corresponding peak has been observed in potential sweep experiments at  $160^\circ C$ , so the kinetics of the reaction must be quite slow. The initial stages of oxide formation on platinum are thermodynamically reversible but kinetically slow [10] and it is possible that the low frequency a.c. technique has in fact resolved this process. Further study is clearly warranted.

## 4.3. The wetting of porous electrodes

Hydrophobic materials such as PTFE are incorporated in fuel cell electrodes to maintain dry channels within the structure and hence permit access by the reactant gas. One question raised by

this practice is how much of the catalyst is not utilized because it is not wetted by the electrolyte? For a typical carbon black electrode, the answer is given by Fig. 5. Initially, the wetted surface area (proportional to the double layer capacitance) is relatively low. After a period of potential cycling, however, the situation is substantially improved (Fig. 5a). The highest degree of wetting achieved by potential cycling is a function of PTFE content (Fig. 5b).

## 5. Conclusions

(1) The low frequency a.c. impedance technique developed in this study can measure the double layer capacitance of a porous electrode.

(2) The double layer capacitance of a high surface area gold powder in 1 M HClO<sub>4</sub> at 25° C resembles that of the smooth metal, over the potential range from 0.3 to 1.0 V.

(3) Measurement of double layer capacitance can follow changes in the interfacial surface area between a porous electrode and the electrolyte.

## References

- [1] J. Bett, J. Lundquist, E. Washington and P. Stonehart, *Electrochim. Acta* **18** (1973) 343;
- J. T. Lundquist and P. Stonehart, *Ibid*, 349; P. Stonehart and J. Lundquist, *Ibid*, 907; K. Kinoshita, J. Lundquist and P. Stonehart, *J. Catalysis* **31** (1972) 325; P. Stonehart, K. Kinoshita and J. A. S. Bett, in M. Breiter (Ed.), *Proc. Symp. Electrocatalysis*, The Electrochemical Society, Princeton, New Jersey (1974) p. 275; K. Kinoshita and P. Stonehart, *Electrochim. Acta* **20** (1975) 101.
- [2] O. S. Ksenzhek and V. V. Stender, *Dokl. Akad. Nauk. SSSR* **106** (1956) 487.
- [3] D. Ferrier, K. Kinoshita, J. McHardy and P. Stonehart, *J. Electroanal. Chem.* **61**, (1975) 233.
- [4] E. G. Gagnon, *J. Electrochem. Soc.* **122** (1975) 521; E. G. Gagnon, *Ibid* **121** (1974) 512; E. G. Gagnon, *Ibid* **120** (1973) 1052; L. G. Austin and E. G. Gagnon, *Ibid* **122** (1975) 70; S. Evans, *Ibid* **113** (1966) 165; D. Berndt, *Electrochim. Acta* **10** (1965) 1067; A. Soffer and M. Folman, *J. Electroanal. Chem.* **38** (1972) 25.
- [5] R. de Levie, *Electrochim. Acta* **8** (1963) 751.
- [6] J. Czech, *Oscilloscope Measuring Technique*, Springer-Verlag, New York, 1965, p. 310.
- [7] C. Cachet, H. Cachet and J-C. Lestrade, *Electrochim. Acta* **19** (1974) 891.
- [8] G. M. Schmid and N. Hackerman, *J. Electrochem. Soc.* **110** (1963) 440.
- [9] K. Kinoshita and J. A. S. Bett, *Carbon* **11** (1973) 403.
- [10] H. Angerstein-Kozłowska, B. E. Conway and W. B. A. Sharp, *J. Electroanal. Chem.* **43** (1973) 9, B. E. Conway and S. Gottesfeld, *J. Chem. Soc., Faraday Trans. 1* (1973) 1060; W. Vogel and P. Stonehart, Unpublished results.